



## 1A Positive Voltage Regulator

### General Description

The CYT8117 series of high performance low dropout voltage regulators are designed for applications that require efficient conversion and fast transient response.

### Features

- 1.1V dropout at full load current ( Typ )
- Low Dropout Performance.
- Guaranteed 1A Output Current.
- Wide Input Supply Voltage Range.
- Over-temperature and Over-current Protection.
- Fixed or Adjustable Output Voltage.
- Rugged 3KV ESD withstand capability.
- Available in SOT-223 Packages.

### Applications

- Active SCSI Terminators.
- High Efficiency Linear Regulators.
- 5V to 3.3V Linear Regulators
- Motherboard Clock Supplies.

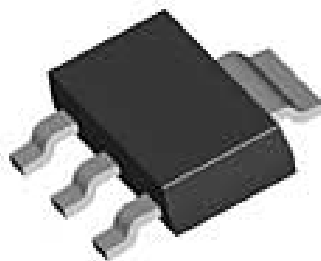

**SOT-223 Package**



### Pin Configuration

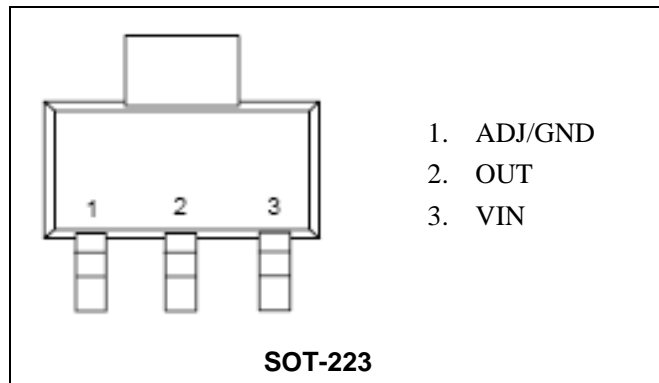

### Typical Application

#### Adjustable Voltage Regulator

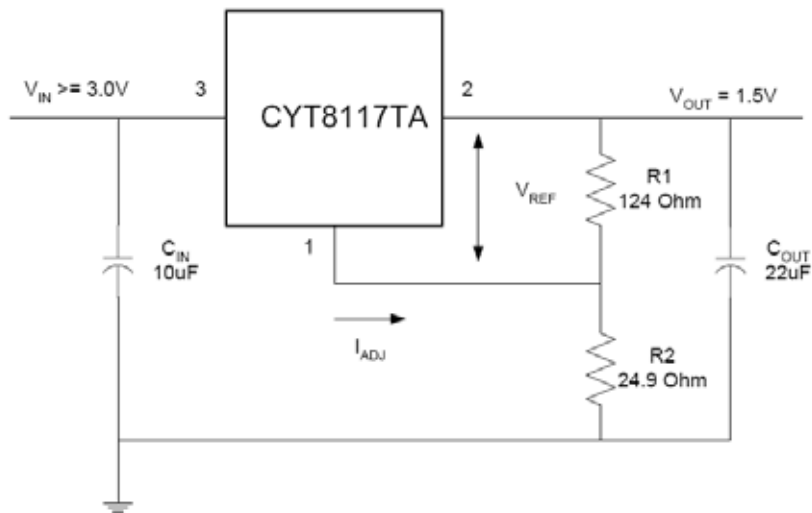

#### Fixed Voltage Regulator

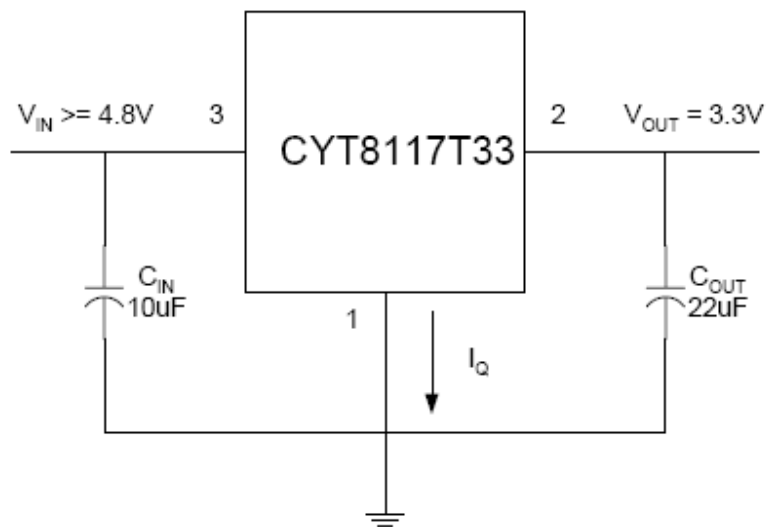



## Ordering Information

CYT8117T- X X -LF

Lead-free

Output Voltage: 15 : Vout=1.5V

18 : Vout=1.8V

25 : Vout=2.5V

30 : Vout=3.0V

33 : Vout=3.3V

A : Vout=ADJ

## Electrical Characteristic

$V_{IN,MAX} \leq 8V$ ,  $V_{IN,MIN} - V_{OUT} = 1.5V$ ,  $I_{OUT} = 10mA$ ,  $C_{IN} = 10\mu F$ ,  $C_{OUT} = 22\mu F$ ,  $T_J = 0 - 125^\circ C$ , unless otherwise specified.

Symbol	Parameter	Conditions	Min	Typ	Max	Units
$V_{OUT}$	Output Voltage <sup>(1)</sup>	( $V_{IN}-V_{OUT}$ )=1.5V , $I_{OUT}=10mA$ , $T_A=25$ CYT8117T15 CYT8117T18 CYT8117T25 CYT8117T30 CYT8117T33	-2%	1.5 1.8 2.5 2.8 3.0	+2%	V
$V_{REF}$	Reference Voltage <sup>(1)</sup> (Adi. Volage Version)	( $V_{IN}-V_{OUT}$ )=1.5V , $I_{OUT}=10mA$ ,	-2%	1.25	-2%	V
VSR	Line Regulation <sup>(1)</sup>	$V_{OUT}+1.5V < V_{IN} < 8V$ $I_{OUT}=10mA$ ,	--	0.3	--	%
$V_{LR}$	Load Regulation <sup>(1)</sup>	( $V_{IN}-V_{OUT}$ )=1.5V , $10mA \leq I_{OUT} \leq 1A$ ,	--	0.4	--	%
$I_{ADJ}$	Adjust Pin Current		--	48	--	$\mu A$
$\Delta I_{ADJ}$	Adjust Pin Current Change	$V_{OUT}+1.5V < V_{IN} < 8V$ $10mA \leq I_{OUT} \leq 1A$ ,	--	0.2	--	$\mu A$
$V_D$	Dropout Voltage <sup>(2)</sup>	$\Delta V_{REF}=1\%$ , $I_{OUT}=1A$	--	1.1	1.4	V
$I_Q$	Quiescent Current	Fixed Output Version	--	10	--	mA
$I_O$	Minimum Load Current		--	4	--	mA
$I_{CL}$	Current Limit		--	1.8	--	A
$T_C$	Temperature Voefficient		--	0.07	--	%/
OTP	Thermal Protection		--	175	--	
$V_N$	RMS Output Noise	$T_A=25$ , $10Hz \leq f \leq 10KHz$	--	0.003	--	%Vo
$R_A$	Ripple Rejection Ratio	$F=120Hz$ , $C_{out}=22\mu F$ (Tantalum),( $V_{IN}-V_{OUT}$ )=3V, $I_{OUT}=1A$	--	35	--	dB

**Notes:** 1. Low duty cycle pulse testing with which  $T_J$  remains unchanged.

2.  $\Delta V_{OUT}$ ,  $\Delta V_{REF} = 1\%$ .



## Absolute Maximum Rating

Parameter	Symbol	Value	Units
Input Supply Voltage	V <sub>IN</sub>	9	V
Thermal Resistance, Junction-to-Ambient SOT-223	Θ <sub>JA</sub>	60	/W
Lead Temperature (Soldering, 10 sec.)	T <sub>LEAD</sub>	260	
Operating Junction Temperature Range	T <sub>J</sub>	0 to +125	
Storage Temperature Range	T <sub>STG</sub>	-40 to +150	

## Application Hints

Like any linear voltage regulator, CYT8117 requires external capacitors to ensure stability. The external capacitors must be carefully selected to ensure performance.

### Input Capacitor

An input capacitor of at least 10μF is required. Ceramic or Tantalum can be used. The value can be increase without upper limit.

### Output Capacitor

An output capacitor is required for stability. It must be placed no more than 1 cm away from the VOUT pin, and connected directly between VOUT and GND pins. The minimum value is 22μF but may be increase without limit.

## Thermal Considerations

It is important that the thermal limit of the package is not exceeded. The CYT8117 has built-in thermal protection. When the thermal limit is exceeded, the IC will enter protection, and VOUT will be pulled to ground. The power dissipation for a given application can be calculated as following: The power dissipation (PD) is

$$PD = I_{OUT} * [V_{IN} - V_{OUT}]$$

The thermal limit of the package is then limited to  $PD(MAX) = [T_J - T_A]/\Theta_{JA}$  where T<sub>J</sub> is the junction temperature, T<sub>A</sub> is the ambient temperature, and Θ<sub>JA</sub> is around 60°C/W for CYT8117. CYT8117 is designed to enter thermal protection at 175°C. For example, if T<sub>A</sub> is 25°C then the maximum PD is limited to about 2.5W. In other words, if I<sub>OUT</sub>(MAX) = 1A, then [V<sub>IN</sub> – V<sub>OUT</sub>] cannot exceed 2.5V.



### Typical Performance Characteristics

Reference Voltage vs Junction Temperature

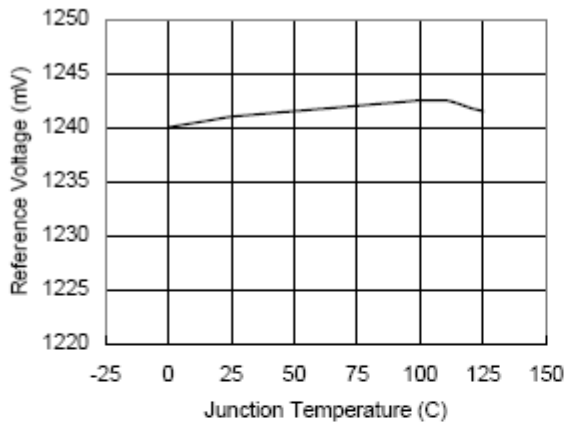

Line Transients

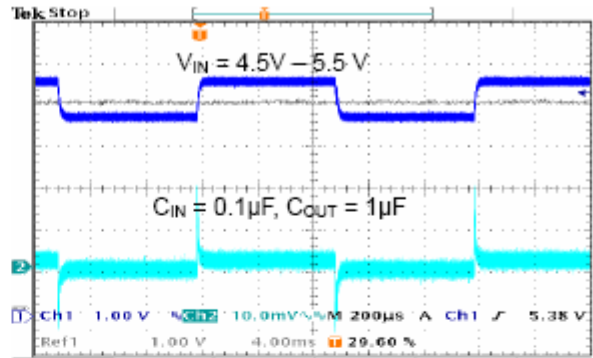

Output Voltage vs Junction Temperature

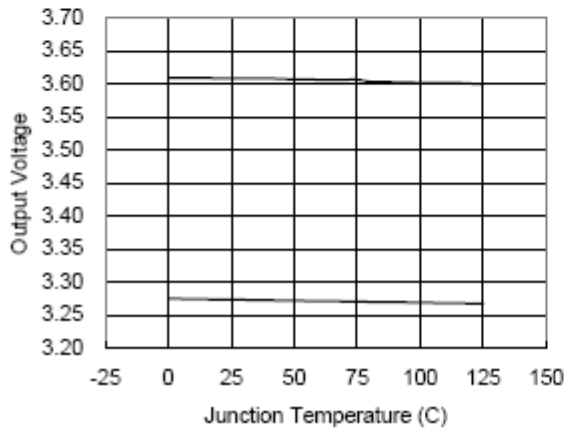

Load Transients

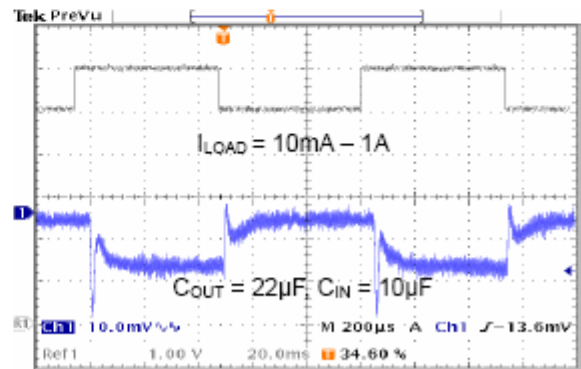

Dropout Voltage vs Output Current

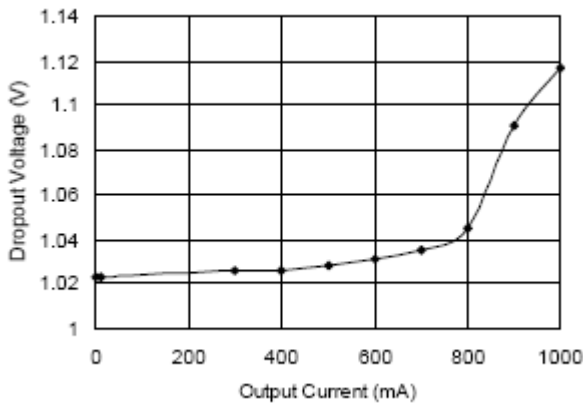



**Outline Drawing for SOT-223**

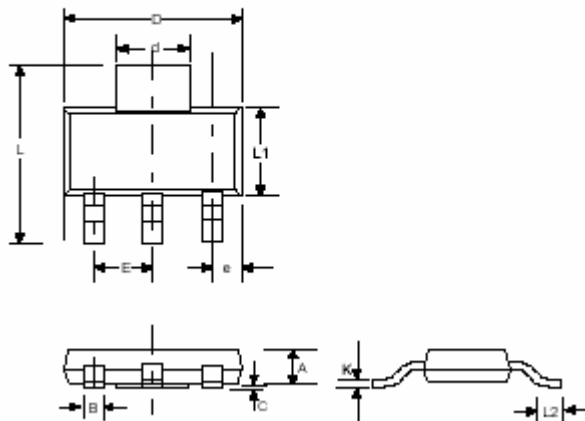

DIM <sup>N</sup>	DIMENSIONS			
	INCHES		MM	
	MIN	MAX	MIN	MAX
<b>A</b>	--	0.071	--	1.80
<b>B</b>	0.025	0.033	0.640	0.840
<b>C</b>	0.012	--	0.31	--
<b>D</b>	0.248	0.264	6.30	6.71
<b>d</b>	0.115	0.124	2.95	3.15
<b>E</b>	--	0.090	--	2.29
<b>e</b>	0.033	0.041	0.840	1.04
<b>L</b>	0.264	0.287	6.71	7.29
<b>L1</b>	0.130	0.148	3.30	3.71
<b>L2</b>	0.012	--	0.310	--
<b>K</b>	0.010	0.014	0.250	0.360